

---

# R1 Extender

## Quick Installation Guide



V1.0 January 2009

---

---

## Copyright

Copyright © 2008 all rights reserved. No part of this publication may be reproduced, adapted, stored in a retrieval system, translated into any language, or transmitted in any form or by any means without the written permission of the supplier.

## About the Installation Guide

This Installation Guide is intended to guide professional installer to install the R1 Extender. It includes procedures to assist you in avoiding unforeseen problems.

## Conventions



- 
- This indicates a warning or caution that you have to abide.
- 



- 
- This indicates an important note that you must pay attention to.
-

---

# Chapter 1 Introduction

## Introduction

The R1 Extender is a high-performance outdoor-deployable wireless bridge that provides wireless connectivity among multiple network locations. It supports Base Station, CPE, PTP and PTMP connectivity. Moreover, the R1 Extender has a built-in 23dBi planar antenna that can deliver up to a 40Km connection. With high throughput and long-distance transmission, the R1 Extender is an ideal backhaul solution for Carriers, Service Providers and Enterprises!



---

# Chapter 2 Preparation before Installation

This chapter describes safety precautions and product information you have to know and check before installing R1 Extender.

## Professional Installation Required

1. Please seek assistance from a professional installer who is well trained in the RF installation and knowledgeable in the local regulations.
2. The R1 Extender is distributed through distributor and system installer with professional technicians and will not be sold directly through retail store.

## Safety Precautions

To keep you safe and install the hardware properly, please read and follow these safety precautions.

1. If you are installing an antenna for the first time, for your safety as well as others', please seek assistance from a professional installer who has received safety training on the hazards involved.
2. Keep safety as well as performance in mind when selecting your installation site, especially where there are electric power and phone lines.
3. When installing your antenna, note the following:
  - ♦ Do not use a metal ladder;
  - ♦ Do not work on a wet or windy day;
  - ♦ Wear shoes with rubber soles and heels, rubber gloves, long sleeved shirt or jacket.
4. When the system is operational, avoid standing directly in front of the antenna. Strong RF fields are present when the transmitter is on.

---

## Product Package

The product package you have received should contain the following items. If any of them are not included or damaged, please contact your local vendor for support.

- R1 Extender with integrated 23dBi antenna ×1
- Mounting Kit ×1
- PoE Injector & Power cord ×1
- Grounding Wire with Screw ×1
- Water Proof RJ-45 Connector Kit ×1
- Quick Installation Guide ×1
- Product CD ×1



### Note:

- 
- Product CD contains Management Tool, Quick Installation Guide and User Manual!
- 

## Mounting Kit

- **Wall/Pole Mounting Bracket**

1. T-Form Bracket ×1
2. Articulation Pole ×1
3. Pole Mount Bar ×1

- **Fasteners**

4. M8×80 Screw ×2
- M8×90 Screw ×1
5. M8 Washer ×3
6. M8 Spring Washer ×3
7. M8 Nut ×1
8. M5×16 Screw ×4
9. M5 Washer ×4

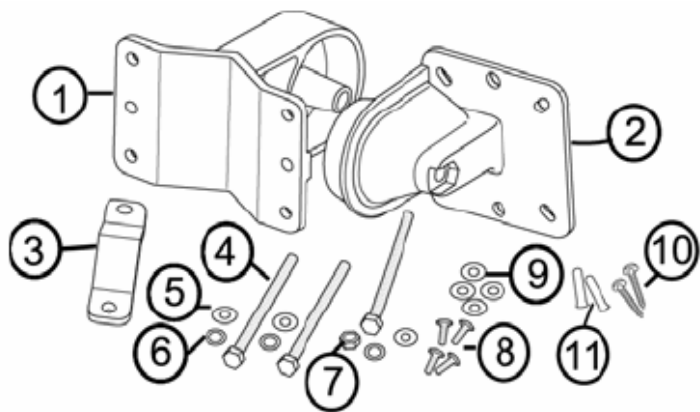

---

10. Wood Screw      ×4 (for Wall Mount)

11. Wall/Gyprock Plug ×4 (for Wall Mount)

## Waterproof RJ-45 Connector Kit

1. Gland              ×1

2. Sealing Nut      ×1

3. Sealing            ×1

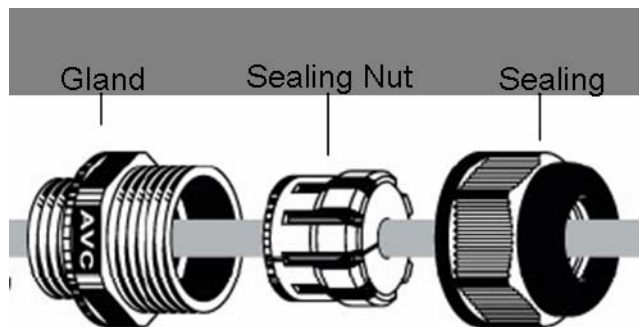

---

# Chapter 3 System Installation

## Assemble the Mounting Bracket

1. Place the main bracket into the seating and use a spanner to fasten the bracket to the R1 Extender with M5×16 screws ⑧ and M5 washers ⑨ provided in the hardware packets;

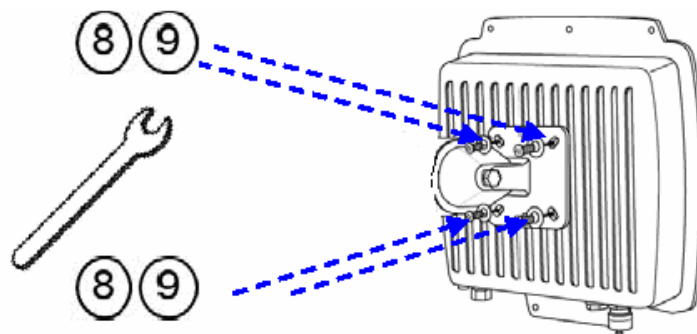

2. Assemble the main bracket by placing articulation pole ② to the T-form bracket ① via a M8×90 ④ screw through the insertion axle and fix with the M8 washer ⑤, spring washer ⑥ and M8 nut ⑦;

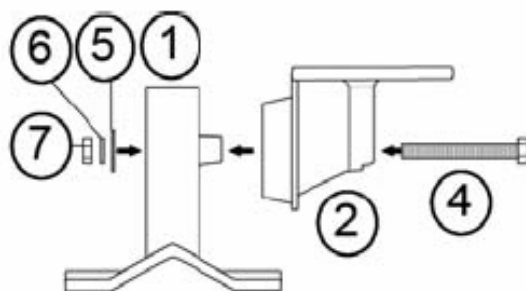

---

## Pole Mounting

1. Install the main bracket and the pole mount bar ③ over the top of the pole by securing the drill holes of the pole mount bar to the main bracket ones and insert two M8x80 ④ screws, spring washers ⑥ and washers ⑤ through the drill holes and main bracket;

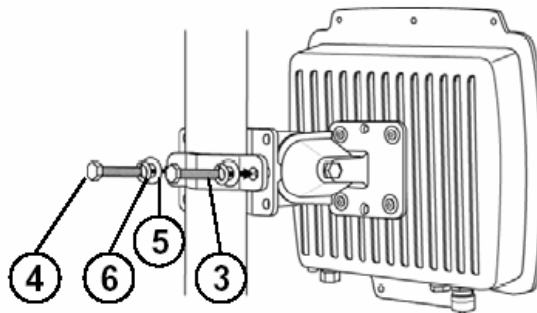

2. Fasten two M8x80 screws ④ and washers ⑤ through the drill holes and main bracket with a spanner;

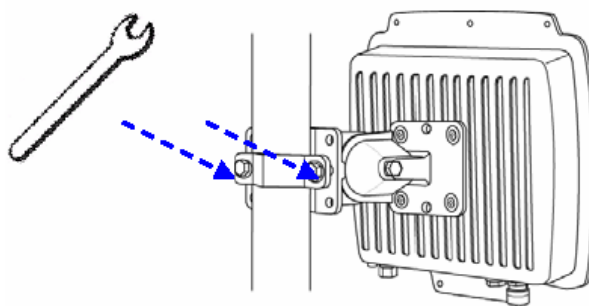

3. Adjust the antenna for appropriate tilt / vertical orientation.

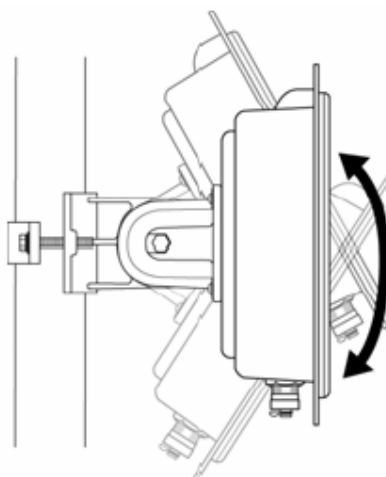

---

## Connect Up

Before installing the Ethernet cable with a waterproof RJ-45 connector, it is recommended that the Cat-5 RJ-45 coaxial cable be used for the bridge to power injector connections.

1. To connect to the hole labeled **PoE+Data**, open the black cover in advance by using a coin or a slotted screwdriver and then screw in the body of the gland and tighten.



2. Slide the sealing nut to the RJ-45 cable from its middle breach and then insert the sealing into the cable.

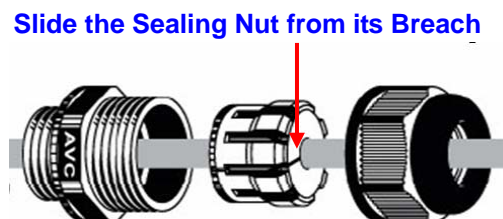

3. Insert the RJ-45 connector and make sure that the locking tab snaps home.

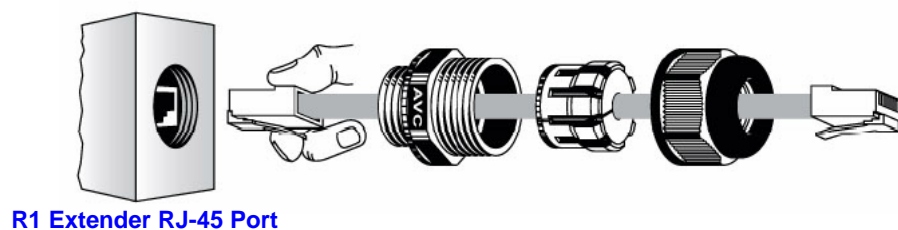

4. Screw the sealing on the gland and tighten.



---

## Ground the wire

The R1 Extender is shipped with a grounding wire. The unit must be properly grounded to protect against power surges. The grounding point can be found on the bottom of the unit. It is supplied with an appropriate grounding lug for attachment to the ODU.



## Power On

To power up the R1 Extender, follow the steps bellow:

1. Plug a user-supplied Cat-5 Ethernet cable from your wired LAN (or a computer) into the power injector RJ-45 jack (**DATA IN**);
2. Plug a user-supplied Cat-5 Ethernet cable from the R1 Extender into the power injector RJ-45 jack (**P+DATA OUT**);
3. Connect the power module to the power injector and plug the AC cord into an AC power receptacle.
4. After being powered on, the device will send out the beep sound lasting about 1.5 seconds, informing you that the R1 Extender powered up! Wait for about 60 seconds the system will be initialized and start working.



 **Warning:**

- Make sure PoE is correctly connected to the RJ-45 port on the R1 Extender labeled PoE+Data. **DO NOT connect to the port labeled "Warning!! No POE"**, otherwise the extender will be severely damaged!



---

# Chapter 4 Configuration

## Connect the R1 Extender to a Local Computer

If you are configuring the R1 Extender locally (without connecting its power injector to a wired LAN), connect a PC to the power injector's Ethernet port using a Category 5 Ethernet cable.

1. Assign a static IP address to your PC which is in the same network segment with the R1 Extender. As the default IP address of this unit is 192.168.1.1, you may choose from 192.168.1.2 to 192.168.1.254.

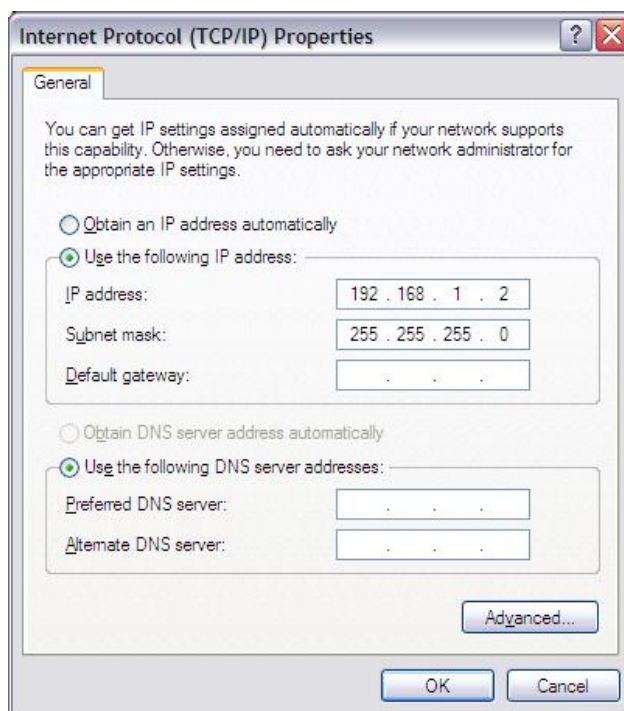

2. Test the link status between your PC and the R1 Extender. Start a command prompt and execute a continuous ping command "ping 192.168.1.1 -t". If ping to the wireless bridge is successful (as shown below), open Internet browser and enter the bridge's IP address in the address field and press Enter.

```
C:\WINDOWS\system32\cmd.exe - ping 192.168.1.1 -t
Destination host unreachable.
Destination host unreachable.
Destination host unreachable.
Destination host unreachable.
Destination host unreachable.
Destination host unreachable.
Destination host unreachable.
Request timed out.
Request timed out.
Request timed out.
Request timed out.
Request timed out.
Request timed out.
Request timed out.
Request timed out.
Reply from 192.168.1.1: bytes=32 time<1ms TTL=64
Hardware error.
Hardware error.
Request timed out.
Reply from 192.168.1.1: bytes=32 time=8ms TTL=64
Reply from 192.168.1.1: bytes=32 time<1ms TTL=64
Reply from 192.168.1.1: bytes=32 time<1ms TTL=64
Reply from 192.168.1.1: bytes=32 time<1ms TTL=64
Reply from 192.168.1.1: bytes=32 time<1ms TTL=64
Reply from 192.168.1.1: bytes=32 time<1ms TTL=64
Reply from 192.168.1.1: bytes=32 time<1ms TTL=64
Reply from 192.168.1.1: bytes=32 time<1ms TTL=64
Reply from 192.168.1.1: bytes=32 time<1ms TTL=64
Reply from 192.168.1.1: bytes=32 time<1ms TTL=64
Reply from 192.168.1.1: bytes=32 time<1ms TTL=64
Reply from 192.168.1.1: bytes=32 time<1ms TTL=64
Reply from 192.168.1.1: bytes=32 time<1ms TTL=64
Reply from 192.168.1.1: bytes=32 time<1ms TTL=64
Reply from 192.168.1.1: bytes=32 time<1ms TTL=64
```

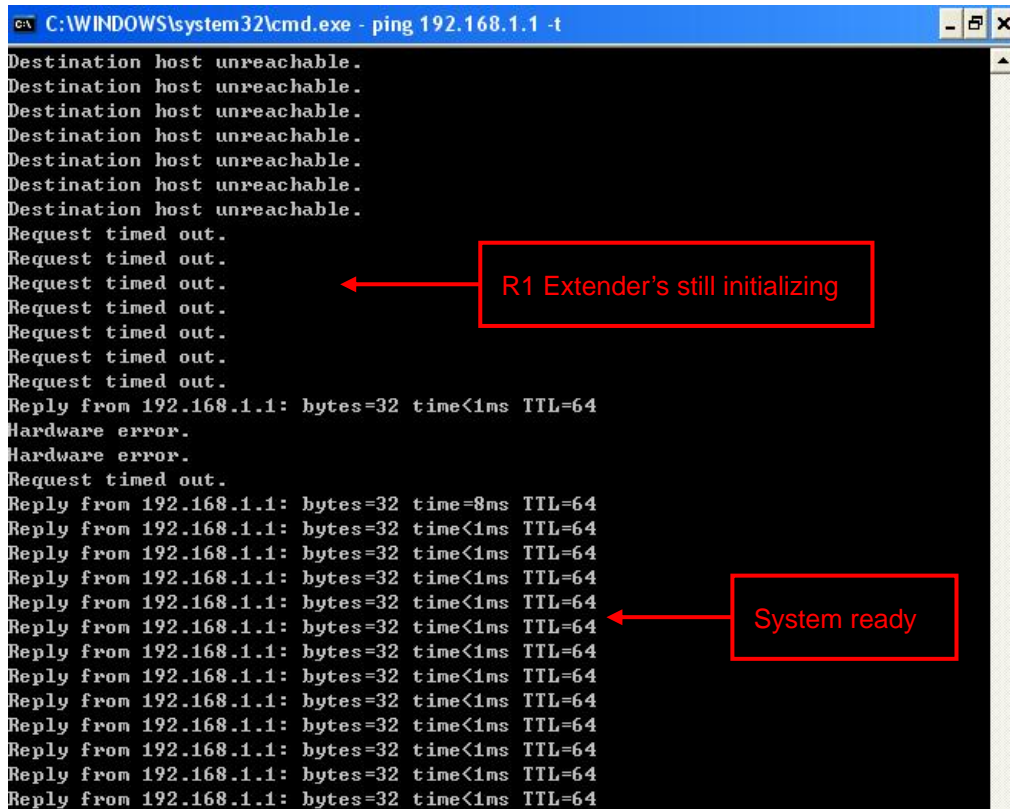

 **Note:**

- 
- Considering convenient configuration, it is recommended to configure local and remote R1 Extender respectively on two computers.
  - TTL time may vary depending on the operating system.
-

---

## How to Establish Wireless Bridge Mode

The R1 Extender supports four operating modes, which are Base Station, CPE, Peer-to-Peer (CSMA) and Peer-to-Peer (TDMA). Normally, Wireless Bridge is the typical mode on this unit. Here we will illustrate how to establish wireless bridge connectivity with R1 Extender.

- Enter the user name (admin) and password (password) to login and make configurations.



 **Note:**

- Due to browser's security trusted sites, 192.168.1.1 might not able to be opened.

You may choose to continue to the website.

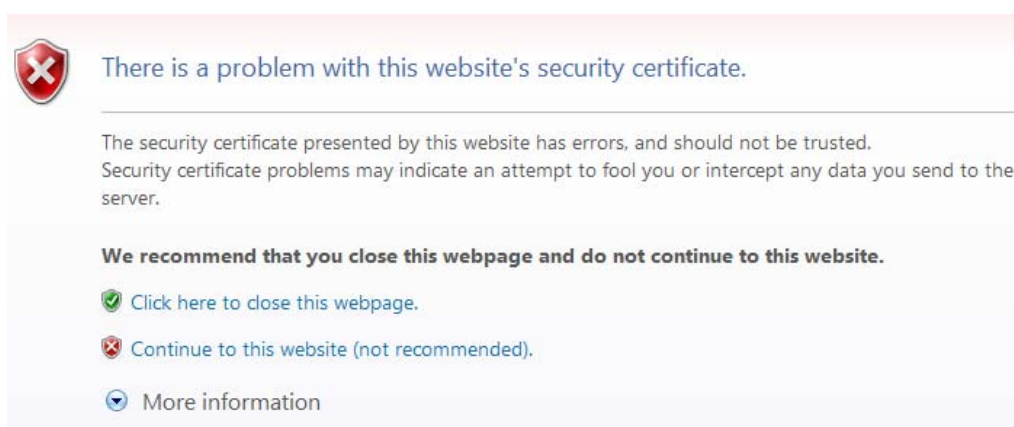

- Open “**Basic Setup**” in “**System**”, set the IP address of two R1 Extenders in the same network segment. e.g. local R1 Extender as 192.168.1.1 and remote R1 Extender as

192.168.1.2 and set the IP Subnet Mask on both as 255.255.255.0

The screenshot shows the 'Basic Setup' page in the ZCOM Rural Connectivity Platform. The page is divided into several sections:

- System**: About, Basic, RADIUS Settings
- Wireless Device Name**: DEVICE123456
- Country / Region**: United States
- Ethernet Data Rate**: Automatic
- Spanning Tree Protocol (STP)**:  Enable  Disable
- Link Aggregation**:  Enable  Disable  
 Full Duplex Two Channels  
(Note: Link aggregation only takes effective when both cards work on P2P model)
- IP Settings**:  Manual  DHCP Client
  - IP Address**: 192.168.1.1
  - IP Subnet Mask**: 255.255.255.0
  - Default Gateway**: 0.0.0.0
  - Primary DNS Server**: 0.0.0.0
  - Secondary DNS Server**: 0.0.0.0

 **Warning:**

- Each IP address is unique within a LAN, otherwise IP collision may occur!

- Open “**Radio**” in “**Wireless**” and you will find the default operating mode is Peer-to-Peer (CSMA). Select to use the Peer-to-Peer (CSMA) operating mode and keep the Channel/Frequency and Bandwidth on both R1 Extenders identical. Click “**Apply**” to save settings.

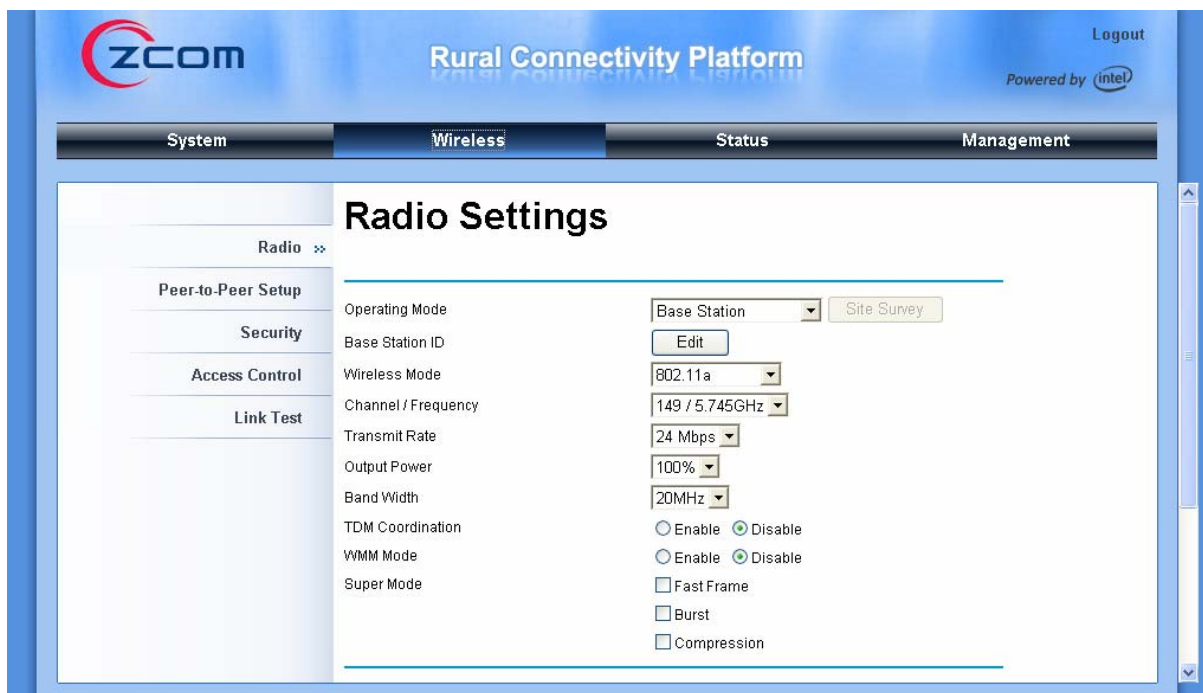

- Login the Web-based interface of remote R1 Extender, open **“About”** in **“System”** and record the wireless MAC address of it.

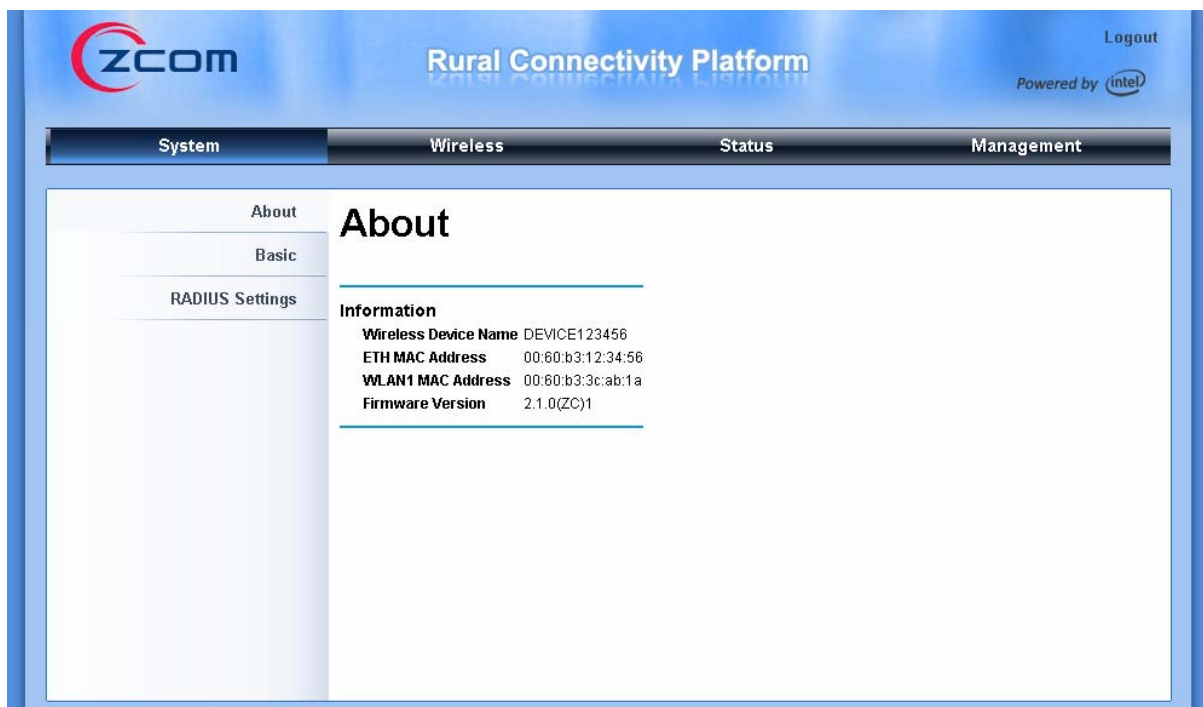

- Login the Web-based interface of local R1 Extender and open **“Peer-to-Peer Setup”** in **“Wireless”**, input the WLAN MAC address of the remote one to **“Remote MAC Address 1”** field and click **“Apply”**;



**Warning:**

- The MAC address on the housing of R1 Extender is the ETH MAC address; therefore it can not be used in Peer-to-Peer links.
- The IP address of your PC should be in the same network segment to the one of bridges.

- Use ping to check whether the link between the two R1 Extender is OK.

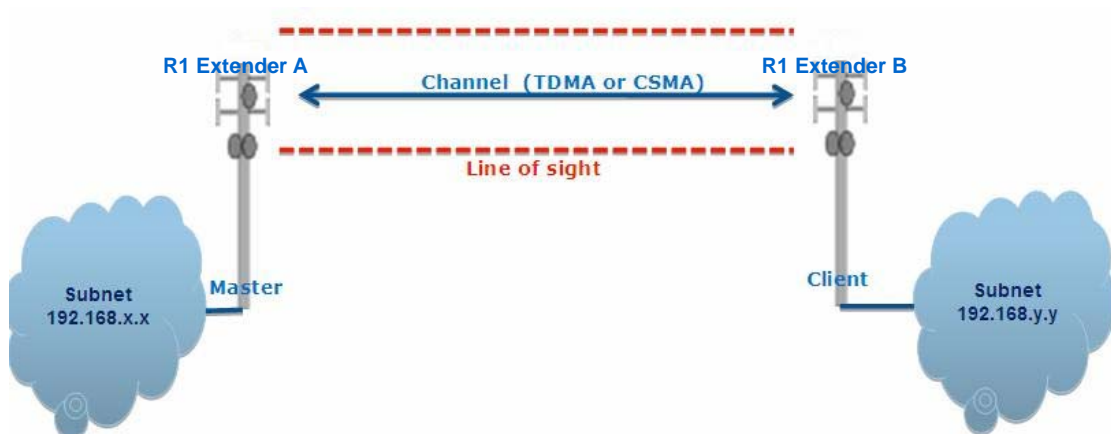

- To get a better wireless connectivity, antenna alignment is strongly recommended after

---

both R1 Extenders are installed long distance apart.

Login the Web-based interface of the local R1 Extender and open “**Peer-to-Peer Setup**” in “**Wireless**”. Hit “**Align Antenna**” button, an antenna alignment tool will popup. Specify the Target RSSI and click “**Start**” to begin the antenna alignment.

## Antenna Alignment Tool

---

Local MAC: 00:60:b3:3c:ab:1a

Remote MAC: 00:60:b3:3c:12:34

Signal Strength:

Current RSSI (dBm): 0

Target RSSI (dBm) :  -65

Transmit Packets: 0

Receive Packets: 0

---

Start

- Fix the local antenna and adjust the remote antenna elevation and horizontal direction. During the adjustment, observe “**Current RSSI**” in local R1 Extender. Fix the remote antenna when it reaches your expectation. Usually, RSSI between -60 and -70dBm indicates rather good signal strength.
- Adjust the local antenna after fixing the remote one. During the adjustment, observe “**Current RSSI**” in the remote R1 Extender. Fix the local antenna when it reaches your expectation.

Congratulations! You have primarily completed configuration on R1 Extender and they can be put into operation. For more advanced configurations, please refer to the User manual.

---

# Chapter 5 Troubleshooting

This chapter provides troubleshooting procedures for basic problems with the R1 Extender.

## Q 1. What if my R1 Extender fails to connect to the remote one?

- **Ethernet Link:** Check the availability of power to the bridge by observing the LED status on the power injector.
  - Green: The R1 Extender is connecting to the backhaul network.
  - Off: The R1 Extender disconnects from the wired network, check whether the power cord and Ethernet cables to the network and bridge are correctly connected.
- **Basic Configurations:** Mismatched basic settings among bridges are the most common cause of connectivity fail. If the bridge does not associate with a remote bridge, check whether options in each device are identical.
- **Security Settings:** Remote bridges attempting to authenticate to your R1 Extender must support the same security options configured in your bridge, such as WEP and WPA (2)-PSK. If your bridge fails to associate with others, check whether the security settings are the same as your bridge settings.
- **Antenna Alignment:** If the methods above are all checked to be correct, you can observe and verify antenna alignment with RSSI value.

## Q 2. What if I would like to reset the unit to default settings?

You may restore factory default settings in “**Backup/Restore Settings**” from “**Management**”

## Q 3. What if I would like to backup and restore my configuration settings?

You may do the backup by generating a configuration file or retrieve the settings you have backed up previously in “**Backup/Restore Settings**” from “**Management**”.

## Chapter 6 Service Information

If you have any further trouble using the R2 Extender or you would like to require additional support, you may visit our website at [www.zcom.com.tw/rpc](http://www.zcom.com.tw/rpc) or you may contact us as below for support:

<b>Z-Com, Inc.</b>			
Taiwan Business Center	7F-2, No.9. Prosperity RD. I Science-Based Industrial Park Hsinchu ,300 Taiwan	Tel: +886-3-5777364 Fax:+886-3-5773359	Sales Contact <a href="mailto:info@zcom.com.tw">info@zcom.com.tw</a> FAE Support <a href="mailto:support@zcom.com.tw">support@zcom.com.tw</a>
<b>Zcomax Technologies, Inc.</b>			
California Business Center	14545 Valley View Ave., Suite "S" Santa Fe Springs, CA 90670	Tel: +1-562-926-4588 Fax:+1-562-926-7885	Sales/Product Inquiries: <a href="mailto:sales@zcomax.com">sales@zcomax.com</a> Tech Support/Questions: <a href="mailto:support@zcomax.com">support@zcomax.com</a>
New Jersey Business Center	98 Ford Road, Suite 3-F, Denville, NJ 07834, USA	Tel: +1-973-664-0310 Fax:+1-973-664-0313	
<b>ZCOMAX - United Kingdom Limited</b>			
European Business Centre	19 Colindale Avenue London NW9 5DS UK	Tel:+44-(0)-20-8982-8200 Fax:+44-(0)-20-8201-3232	Sales Contact <a href="mailto:sales@zcomax.co.uk">sales@zcomax.co.uk</a> FAE Support <a href="mailto:support@zcomax.co.uk">support@zcomax.co.uk</a>
<b>Z-Dotcom, Inc</b>			
China Business Centre	168 Long Pan Zhong Road, Jiangsu Software Park, Suite 118 Nanjing, China 210002	Tel: +86-25-84661300 Fax:+86-25-84661313	Sales Contact <a href="mailto:sales@zcom.com.cn">sales@zcom.com.cn</a> FAE Support <a href="mailto:support@zcom.com.cn">support@zcom.com.cn</a>